

All Dimensions Are
In mm Unless Stated

Notes:

- Minimum 44mm Door Thickness
- 20mm Thick Hardwood Lipping To Leaf Top Edge (Min 640kg/m³)
- 20mm Thick Stop To Frame Head (Planted On Or Rebated)
- Soft/Hardwood Frame (Min 510kg/m³), Min 32mm Thick Frame Section
- All Rebates For Closer To Be Fitted With Manufactures IP.114 Intumescent As Per Manufactures Instructions. See CF5902
- **Dimensions Include Allowances For Intumescent Material**

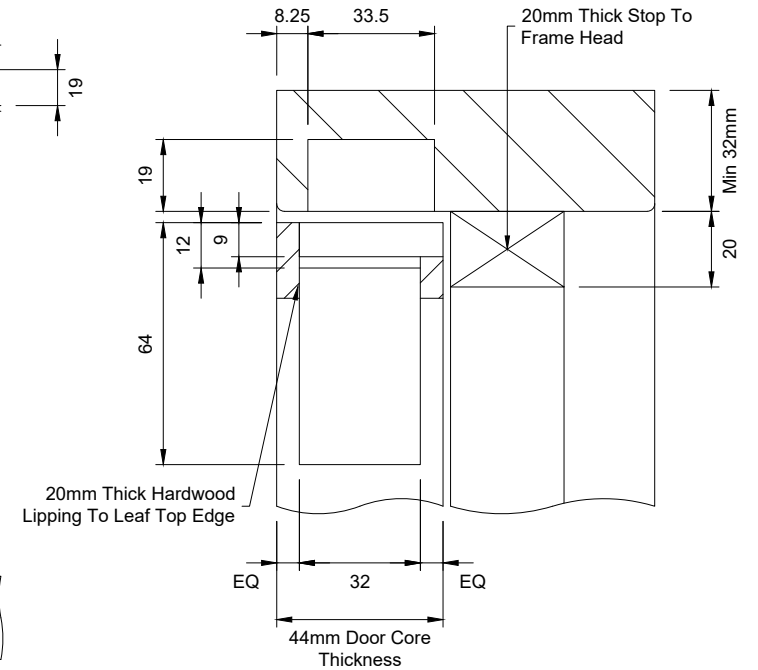
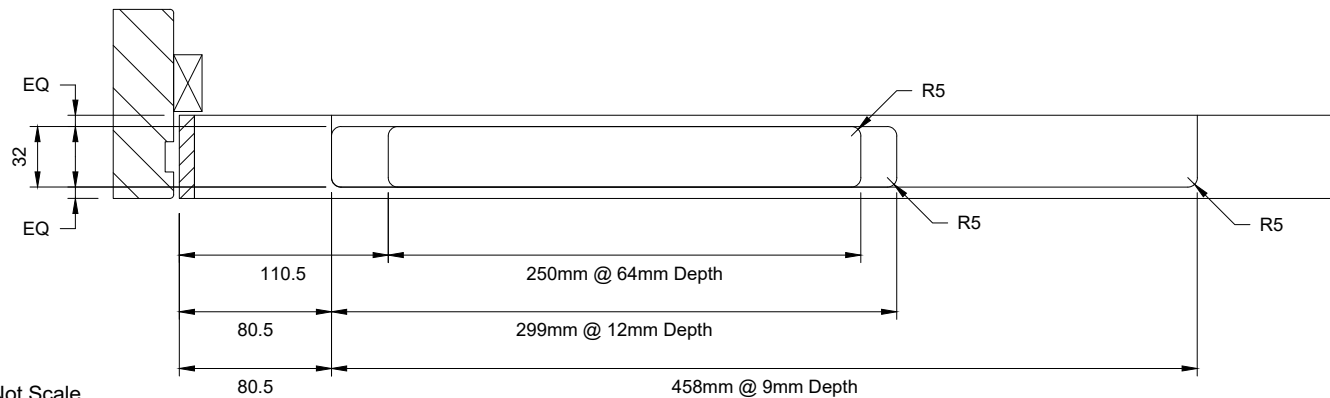
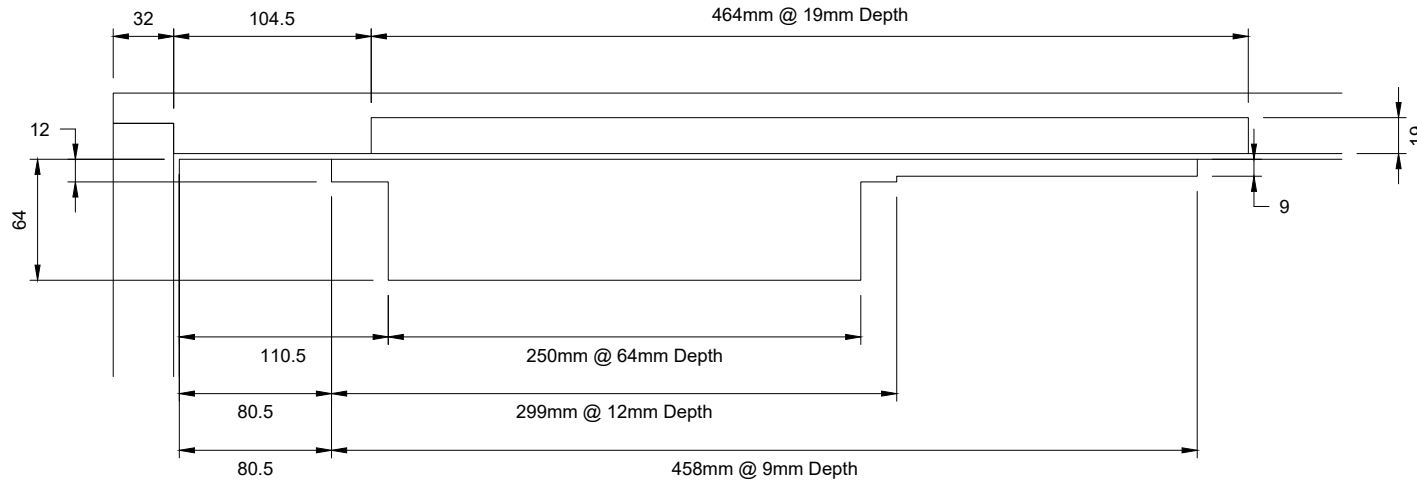
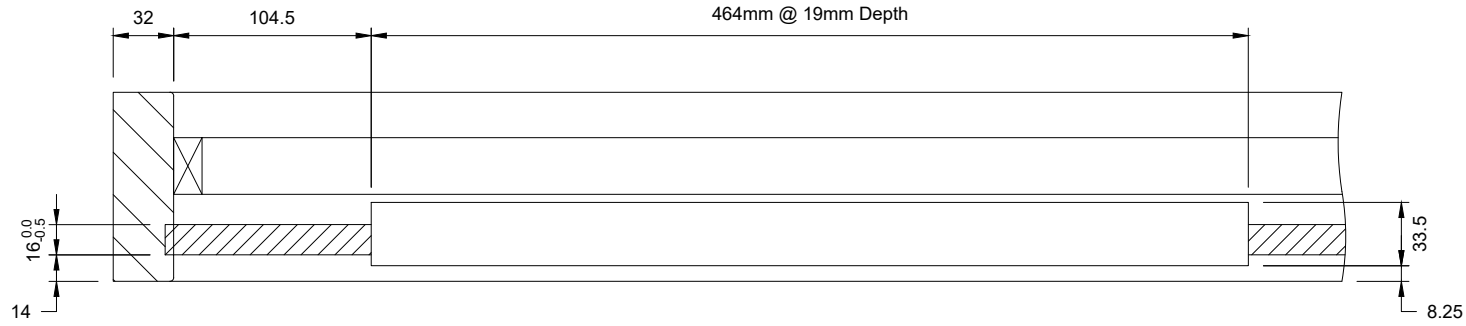

Do Not Scale.

If In Doubt Ask!

Description: **Concealed Closer Machining - FD30 - 44mm Core - Rutland ITS.11204 2-4**

Drawn By: **O BOOY**

Approved: **Approved**

Date: **22/05/2026**

Cert / FoA Ref:

Drawing No:

© Doorpac Ltd

Size: **As Above**

Rev:

Fire Rating:

DP24768



Job No:

Tolerance: **±0.25mm**

FD30

Rev01